

**Southern California Joint Pole Committee**

279 E. Arrow Hwy., Suite 104

San Dimas, CA 91773

Phone (909) 599-3801

**July 16, 2025**

A meeting of the **ad hoc Compliance Committee** took place on the above date, **at 10:43 a.m. via teleconference. Those in attendance were:**

Ms. Aarize Dizon	Crown Castle NG West Inc.
Mr. Jeremy Effinger	Crown Castle NG West Inc.
Ms. Jacqueline Costa	Crown Castle NG West Inc.
Ms. April DeBarge	Southern California Edison
Ms. Carla Stephen	Southern California Edison
Ms. Marisol Bailey	Southern California Edison
Mr. Michael Pearson	Southern California Edison
Mr. Samuel Picazo	Southern California Edison
Ms. Shelby Mulvehill	Southern California Edison
Ms. Silvana Ray	Southern California Edison
Mr. Kristoffer Scheetz	Southern California Edison
Mr. Lex Treepaisan	Frontier Communications
Ms. Kay Black	AT&T California
Mr. Todd Dailey	AT&T California
Mr. Alvin Robielos	AT&T California
Mr. Aaron Cochran	AT&T California
Ms. Joy Young	AT&T California
Mr. Julian Ruiz	AT&T California
Ms. Veronica Casanova-Romero	AT&T California
Mr. Michael Truong	City of Burbank
Mr. Joseph DeLaTorre	City of Azusa
Mr. John Vu	City of Anaheim
Mr. Alex Parra	City of Riverside
Ms. Claudia Arellano	City of Vernon
Mr. Ben Coffey	City of Banning
Ms. Yesenia Delgado	Time-Warner Cable
Mr. Nick Van Stryk	City of Vernon (Petrelli Electric)
Ms. Maria Ortiz	MCI Metro ATS/MCI Telecommunications/XO Communications
Mr. Jeremy Harmon	Verizon Wireless
Ms. Alicia Smith	Sprint Nextel/Sprint Communications
Ms. Linda McLean	Extenet Systems
Ms. Heidi Seropian	Extenet Systems

Ms. Angela Pranata	Committee Staff
Ms. Kathleen Allen	Committee Staff
Ms. Anali Spencer	Committee Staff

Ms. Dizon called the meeting to order at 10:43a.m.

**Agenda Item 1 – Review of prior month’s meeting minutes**

Ms. Dizon inquired if the members had any questions, comments, or concerns regarding the prior meeting minutes.

There were no comments or concerns from any members.

**Agenda Item 2 – Item 1630: CPUC Updates (2/14/17– title changed 04/17/2019) – The Admin Board decided this topic requires greater discussion and is to remain open (8/14/2018).**

Ms. Dizon opened the discussion to CPUC updates and stated that this item is on hold for now.

There were no comments or concerns from any members.

**Agenda Item 3 – Item 1658: Environmental Issues (1/16/2019, moved from Admin Board on 1/15/2020)**

Ms. Dizon opened the discussion to Environmental Issues. She asked the members if they had anything to bring up at this time.

There were no comments or concerns from any members.

**Agenda Item 4 – Item 1800: Approved Maintenance Program Review (K. Black – AT&T CA – 2/19/2025)**

Ms. Dizon opened the discussion to the Approved Maintenance Program Review. She stated that at the last action item was for the members were to review this internally with their teams. Ms. Black stated she sent an item to Ms. Pranta to be added to the packet. Ms. Dizon stated that Crown Castle is pending response from their leadership team. Ms. Black started to review the additional edits added to the packet (see attached) and stated that AT&T Californias edits are in red. She stated that AT&T California is trying to simplify which item numbers utilities should use for their intrusive tests and maybe discuss what a specific item number is. Ms. Black stated for A, B, and C AT&T California is trying to define an industry standard and wanted to see if they can come up with an agreement for this. Everyone’s intrusive tests would fall under one of the three categories. She asked the members if this makes sense according to the members intrusive testing or if there are scenarios that potentially do not fit within the listed categories. Ms. Black explained that the preference for using “ORS” standards under the OR is due to their recognition as industry benchmarks. Other utilities have attempted to apply standards from above the OR, particularly

in cases involving partial digs combined with bore methods. Mr. Ruiz with AT&T California stated that there is one thing that they have discussed internally that he would like to add. He stated that AT&T California is trying to share what they have learned from their own program and the results from the vendor that they use and trying to make sense of this and what it looks like for everyone. He stated that the intention is to initiate some conversation and learning to see if they can come up with something that make sense for everyone. He stated that what AT&T California has noted over the last five years is that a lot more companies are getting active with establishing their own programs and they have seen some pricing that is really expensive and they have seen the total spent in those areas go up exponentially year after year not just for base owners but for anyone participating in any kind of pole ownership. This is an area that AT&T California would like to start to get some solid understanding and so all members know what is included in the data they are receiving and what they are paying for. He stated that internally they are getting questions that they do not have great answers for. They would like to know what other benefits they are getting and capture that data to use it to verify own pole locations. He stated with the CPUC orders coming through and pending they would like to take advantage of what they are paying for whether it be their own program or a shared program. AT&T California would like to be clear on what they are getting and take full advantage of whatever the pole test is and data that comes from it. Mr. Treepaisan stated that what was displayed on the screen seems to memorialize GO 165's Table 1 in words and he likes that. Ms. Dizon asked if there were any other comments or concerns. Ms. Black stated if there were no other comments or concerns on this, there was further information she would like to share on this before moving on. Ms. Black stated that the Pole Marking has also been edited. She stated AT&T California is finding pole retagging and visibility strips being applied five to ten times a year to the same pole. Ms. Black stated that AT&T California would like to add verbiage that the item number can only be used once unless there is a special agreement. She stated AT&T California does understand there could be a pole on a specific corner or area that gets vandalized or trucks hitting it ensuing the need for the pole being tagged multiple times a year. She stated they would like that conversation before they are presented with the shared cost. Ms. Black stated the last item that was not included was how to get a copy of these results which will be brought up during the Computer Committee meeting.

There were no further comments or concerns from any members.

## **Agenda Item 5 Miscellaneous -**

### Grounding on Steel Poles

Ms. Dizon asked if the members had the chance to look at the specifications on Grounding on Steel Poles sent out by Ms. Pranata and if there

were any comments, questions, or concerns. Mr. Treepaisan and Ms. Ray stated they did not have the opportunity to review this beforehand and were currently reviewing the information. Ms. Dizon stated the members could take this back and review to further discuss at the next month's Compliance Committee meeting.

There were no further comments or concerns from any members.

#### Other Miscellaneous Items

Ms. Dizon asked if there were any other miscellaneous items.

There were no questions or comments.

#### **Agenda Item 6 - Review of Action Items/JPA Alerts**

- Ms. Black to send out additional edits for Item 1800 unauthorized costs items.
- Members are to review the grounding on steel poles specifications to discuss for the next meeting.

The meeting adjourned at 10:55 a.m. until August 20, 2025.

Transcribed by Anali Spencer - Committee Staff

## Item 1800 - Maintenance Authorized Cost Items

Edits are red –

### 12. Pole **Intrusive** Inspections and Treatment

- (a) Reserved for future use
- (b) Partial Dig. – **on poles over 15 years**..... 261
- (c) Sound and Bore - **on poles over 15 years** ..... 261
- (d) Full Treatment - **on poles over 15 years** ..... 261
- (e) Reject - **on poles over 15 years** .....261

~~Note: May only be billed once every 5 years (Effective May 2011).~~

- (f) Partial Dig. – on poles with pass results 20 year ago.....xxx
- (g) Sound and Bore - on poles with pass results 20 year ago ..... xxx
- (h) Full Treatment - on poles with pass results 20 year ago ..... xxx
- (i) Reject - on poles with pass results 20 year ago.....xxx

- (~~f~~) Re-inspection of reinforced poles (may only be billed once every 10 years, effective 06/01/2011) .....417

### 15. Pole Marking – Maintenance items only (Revised 11/17/2021)

- (a) Re-Tagging....**only once per year, unless special agreement**..... 161
- (b) Replacing Visibility Strips ..... **only once per year, unless special agreement**..... 163

Material List: M480-02

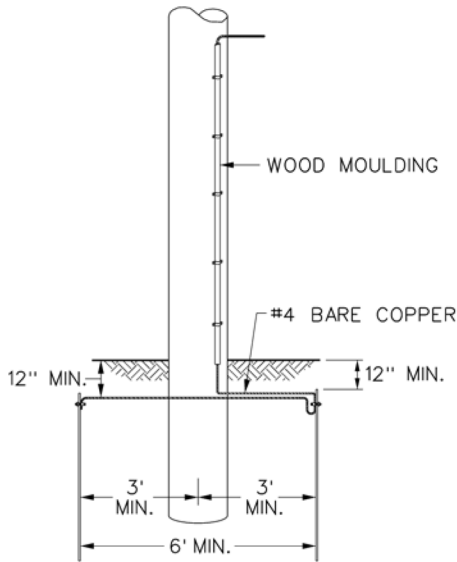

**C480-001**  
WOOD POLE

NOTE:  
Non-wood covered  
ground wire cannot be  
put in climbing space.

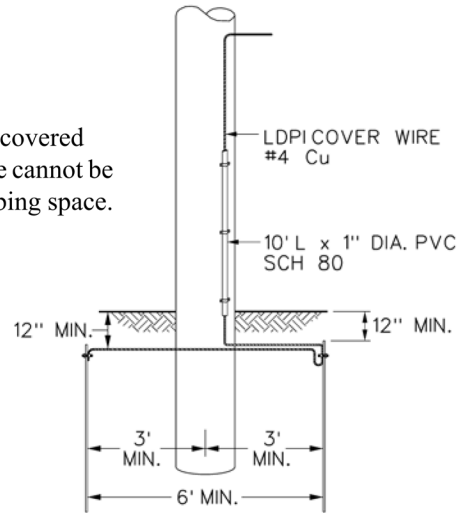

**C480-003**  
WOOD & FIBERGLASS POLE  
(10' PVC CONDUIT &  
#4 CU LDPI COVERED WIRE)

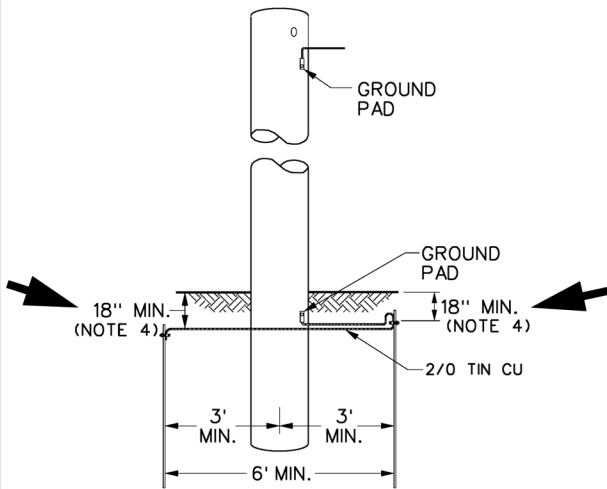

**C480-004**  
CONCRETE AND STEEL  
POLE

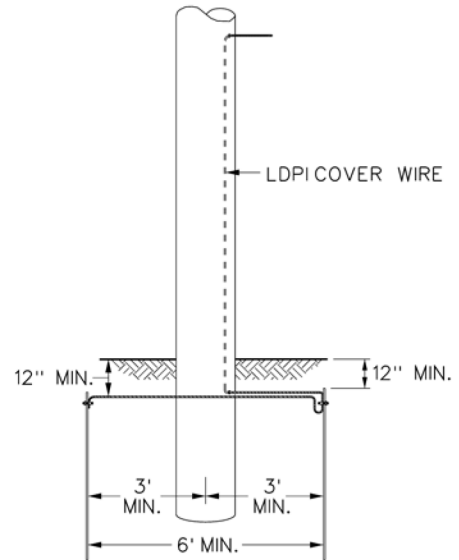

**C480-003**  
FIBERGLASS POLE

**NOTES:**

1. Vertical runs, risers, ground wires and hardware of supply lines shall have a clearance of not less than 1-1/2 inches from similar equipment of communication lines and from similar equipment of supply lines of different ownership.
2. Vertical runs, risers, ground wires and hardware shall be so located that they do not interfere with the free use of the pole steps.
3. The grounding conductor from the ground rod (ground electrode) to the messenger shall be continuous, unless suitable electrical compression connections are used.
4. The top of the rods and attached wires shall be 18" below the final ground grade.

➡➡ **REVISION**

**C480-02**

Issued Date: 01/31/12  
Revised Date: 03/11/13

Approved by

*Dehan Bandy* JST  
P.E. LIC. E-20215

**C480-02**

# Item 1800 - Maintenance Authorized Cost Items

Edits are red –

## 12. Pole **Intrusive** Inspections and Treatment (**Only one item number per test.**)

(a) Reserved for future use	
(b) Partial Dig	261
(c) Sound and Bore -	261
(d) Full Treatment	261
(e) Reject -	261

~~Note: May only be billed once every 5 years (Effective May 2014).~~

- a. Poles Excavated – Treated Reject, Full Excavation or Dug Reject – poles over 15 yrs
- b. Poles Not Excavated – Sound & Bore, Visual – poles over 15 yrs
- c. Poles Partially Excavated – Partial Excavate – poles over 15 yrs
- d. Poles Excavated – Treated Reject, Full Excavation or Dug Reject – poles w/pass 20 yrs ago
- e. Poles Not Excavated – Sound & Bore, Visual– poles w/pass 20 yrs ago
- f. Poles Partially Excavated – Partial Excavate– poles w/pass 20 yrs ago

~~(f,g)~~ Re-inspection of reinforced poles (may only be billed once every 10 years, effective 06/01/2011) .....417

## 15. Pole Marking – Maintenance items only (Revised 11/17/2021)

(a) Re-Tagging....only once per pole per 12 mos, unless special agreement.....	161
(b) Replacing Visibility Strips ..... only once per year, unless special agreement.....	163